

CS-23-221

CHANGE ORDER REQUEST FORM

Ameila Island Pkwy Trail Ph. 1 / BCFLT / 437334-1
PROJECT

No. 01

NASSAU COUNTY BOARD OF COUNTY COMMISSIONERS
COUNTY Contract / Purchase Order No.: CM3373
CONTRACTOR: CGC, Inc.

ENGINEER / ARCHITECT: DRMP

The undersigned parties agree to amend this Contract to add an additional \$2,912.50 to the contract price.

Attachments:

<p>CHANGE IN CONTRACT PRICE:</p> <p>Original Contract Price \$ <u>998,747.00</u></p> <p>Net change from previous Change Orders No. <u>0</u> to No. <u>1</u> \$ <u>0.00</u></p> <p>Contract Price prior to this Change Order \$ <u>998,747.00</u></p> <p>Net Increase (decrease) of this Change Order \$ <u>2,912.50</u></p> <p>Contract Price with all approved Change Orders \$ <u>1,001,659.50</u></p>	<p>CHANGE IN CONTRACT TIMES:</p> <p>Original Contract Times <u>310 days (5/22/2024)</u></p> <p>Ready for Final Payment: <u>310 days (5/22/2024)</u> (days and dates)</p> <p>Net change from previous Change Orders No. <u>0</u> to No. <u>1</u> <u>0</u> (days)</p> <p>Contract Times Prior to this Change Order</p> <p>Substantial Completion: <u>280 days (4/22/2024)</u></p> <p>Ready for Final Payment: <u>310 days (5/22/2024)</u> (days and dates)</p> <p>Net Increase (decrease) of this Change Order <u>0</u> (days)</p> <p>Contract Times with all approved Change Orders</p> <p>Substantial Completion: <u>280 days (4/22/2024)</u></p> <p>Ready for Final Payment: <u>310 days (5/22/2024)</u> (days and dates)</p>
--	--

RECOMMENDED:

By: Ric Burn
Engineer/Architect (Authorized Signature)

Date: _____

APPROVED:

By: Raymond Albany
COUNTY (Authorized Signature)

Date: _____

ACCEPTED:

By: Jonathan B. Barton
Contractor (Authorized Signature)

Date: _____

CHANGE ORDER APPROVAL FORM

PROJECT: C0044 / BCFLT / 437334-1-58-01 / G1W64 / Amelia Island Pkwy Trail Ph. 1

CHANGE ORDER NUMBER: 01

DATE: 12/12/2023

CONTRACT NUMBER: CM3373

TO CONTRACTOR: CGC, Inc.

Description: Raise existing manhole at Station 43+87 (27L)

Reason for Change Order:

To maintain the form and function of the existing stormwater drainage structure in the vicinity of Station 43+87 (27L) for an existing cross drain. The manhole ring and cover were buried in the shoulder and were only revealed during clearing, grubbing and excavation operations to construct the paved, multi-use trail.

Original Contract Sum.....	\$	<u>998,747.00</u>
Net Change by Previous Change Order/Supplemental Agreement.	\$	<u>0</u>
Contract Sum Prior to This Change Order.....	\$	<u>998,747.00</u>
 Amount of this Change Order (Add).....	 \$	 <u>2,912.50</u>
 New Contract Sum Including this Change Order.....	 \$	 <u>1,001,659.50</u>

The Contract Time will be **increased or decreased (select one)** 0 days
 Previous Substantial Completion: 4/22/2024 Previous Final Completion: 5/22/2024
 New Substantial Completion: 4/22/2024 New Final Completion: 5/22/2024

APPROVED BY: Robert Companion DATE: 1/25/2024
 Department Head/Managing Agent

APPROVED BY: Janice Belmonte DATE: 1/26/2024
 Procurement

APPROVED BY: Chris Lacambra DATE: 1/25/2024
 Office of Management and Budget

APPROVED BY: Denise C. May DATE: 1/30/2024
 County Attorney

APPROVED BY: [Signature] DATE: 1/30/2024
 County Manager

DJ 1/30/2024

APPROVED BY: N/A
John F. Martin, Chairman

DATE: _____

ATTEST: N/A
John A. Crawford, Clerk of Courts

DATE: _____

Account No(s): 63470541-563369 BCFLT

JF 1/25/2024

ATTACHMENT A

Invitation to Bid

Amelia Island Trail Segment 1

NC23-010-ITB

SECTION 00 63 15

CONTRACTOR'S REQUEST FOR INFORMATION

TO: Ric Burn, Project Administrator, DRMP (CEI)

FROM: Jonny Barton, Project Manger (CONTRACTOR) DATE: 8/29/2023

CONTRACTOR REQUEST FOR INFORMATION NO.: 2 - Storm Sewer Manhole Conflict

PROJECT NAME: Amelia Island Trail Segment 1

CONTRACT NUMBER: Nassau County: CM3373
FDOT: G1W64 / 437334-1-58-01 PURCHASE ORDER NO.: CS-22-208

QUESTION:

During grass stripping operations a storm sewer manhole was uncovered at approximately STA 43+87, 10 feet west of the edge of pavement of Amelia Island Parkway. This places the manhole in the center of the proposed trail segment and conflicting with the pavement section. Please provide direction on how to proceed. A photograph of the manhole has been attached to this document

BY: 
Jonathan Barton, Project Manager - CGC, Inc.

DATE: 8/29/2023

REPLY:

BY: _____ DATE: _____

Section 00 63 15-1

<input checked="" type="checkbox"/> REVIEWED, NO COMMENTS	<input type="checkbox"/> REJECTED, REVISE AND RESUBMIT
<input type="checkbox"/> REVIEWED, COMMENTS AS NOTED	<input type="checkbox"/> NOT REVIEWED

REVIEW OF THIS REQUEST FOR INFORMATION IS LIMITED TO GENERAL COMPLIANCE WITH THE INFORMATION OR REQUIREMENTS IN THE PROJECT PLANS AND SPECIFICATIONS ONLY. REVIEW SHALL NOT RELIEVE THE CONTRACTOR FROM RESPONSIBILITY OF DETAILS OF DESIGN, DIMENSIONS, JOB CONDITIONS, CONSTRUCTION MEANS AND METHODS, COORDINATION WITH OTHER TRADES, OR ANY OTHER REQUIREMENTS OF THE PLANS, SPECIFICATIONS, OR CONTRACT FOR THIS PROJECT. ANY NOTATIONS ON THIS SUBMITTAL MADE BY DRMP SHALL NOT BE CONSTRUED TO AUTHORIZE ADDITIONAL WORK OR COST.



BY: Alaric (Ric) T. Burn, PA, DRMP

ATTACHMENT B



November 16, 2023

Mr. Ric Burn, Project Administrator
DRMP
1625 Summit Lake Drive, Suite 200
Tallahassee, FL 32317

Re: Amelia Island Trail Segment 1
Amelia Island Parkway, Fernandina Beach, FL 32034
Contract No. CM3373
FDOT FPN: G1W64-437334
CGC, Inc. Project #: C-23-06
Cost Proposal #1 – Raise Existing Manhole (Revision 1)

Dear Mr. Burn,

CGC, Inc. submits the following proposal to raise the existing manhole riser as directed in the response to RFI #02 and discussed in our phone conversation on October 31st to sit flush with the asphalt surface course. No specifications have been provided to CGC, Inc.

We include in our scope of work:

1. Excavate limerock to expose and remove the existing manhole ring and cover.
2. Furnish and install precast riser rings on top of existing riser. Cut sheets of riser rings attached.
3. Reinstall manhole ring and cover at design elevation for finish asphalt, recompact limerock and install base course and surface course per the project plans and specifications around cover.

We exclude from our scope of work:

1. Permits and or fees of any kind.
2. Additional maintenance of traffic outside of current shoulder closure.
3. Night and/or weekend work. (Work to be performed during normal work hours).
4. Removal and replacement of any unsuitable or contaminated material.
5. Repair of unforeseen conduit/utilities.
6. Additional sodding if required.

7036 W. 12th Street / Jacksonville, Florida 32220 / Office (904) 783-4119 Fax (904) 783-3401

Email: office@cgccivil.com

CGC1524573 CUC1225351

7. Additional erosion control if required.
8. Any Items not specifically listed in the scope of work above.

Total Lump Sum Price = \$2,912.50

We thank you for the opportunity to provide this proposal. Should you have any questions and/or direction, please contact this office.

Sincerely,

A handwritten signature in blue ink, appearing to read 'Jonathan Barton', with a long horizontal flourish extending to the right.

Jonathan Barton
Project Manager

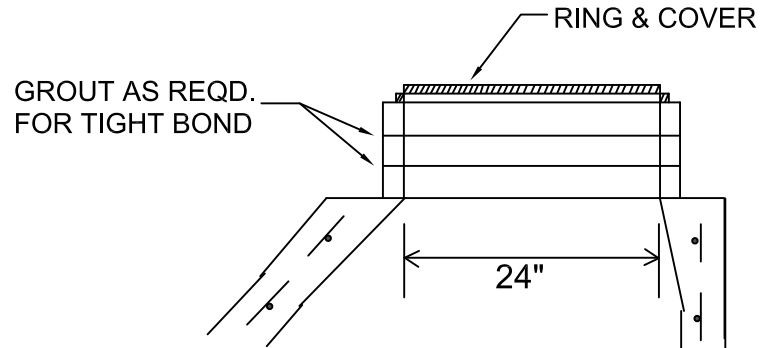
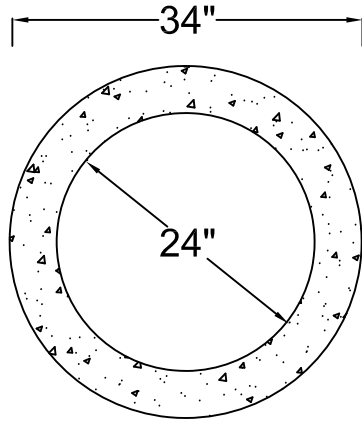

FIELD WORK DETAIL

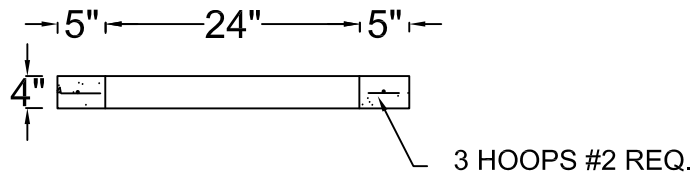
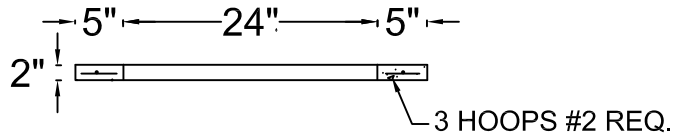

SPECIFICATIONS:

1. 4,000 PSI CONCRETE
2. REINFORCING STEEL: # .220 WIRE
3. AVAILABLE IN 2" & 4" THICKNESS

 STANDARD PRECAST, INC. STANDARD for QUALITY	STRUCTURE # _____ 15 EACH
	TYPE STRUCTURE: _____ 4" GRADE RINGS
	JOB NAME: _____
	CONTRACTOR: _____

Certificate Of Completion

Envelope Id: 5161193BC08C4B9E8CF0E97AF22C9ED0	Status: Completed
Subject: Complete with DocuSign: CM3373 Change Order 01 Approval Form and Requisition	
Source Envelope:	
Document Pages: 8	Signatures: 9
Certificate Pages: 6	Initials: 4
AutoNav: Enabled	Envelope Originator:
Envelopeld Stamping: Enabled	George Murray
Time Zone: (UTC-05:00) Eastern Time (US & Canada)	gmurray@nassaucountyfl.com
	IP Address: 50.238.237.26

Record Tracking

Status: Original	Holder: George Murray	Location: DocuSign
1/25/2024 9:02:04 AM	gmurray@nassaucountyfl.com	

Signer Events

Signature	Timestamp
Robert Companion RCompanion@nassaucountyfl.com Deputy County Manager - County Engineer Nassau County BOCC Security Level: Email, Account Authentication (None)	Sent: 1/25/2024 9:18:15 AM Viewed: 1/25/2024 9:43:55 AM Signed: 1/25/2024 9:44:17 AM
Signature Adoption: Pre-selected Style Using IP Address: 50.238.237.26	

Electronic Record and Signature Disclosure:
Not Offered via DocuSign

Tracy Poore tpoore@nassaucountyfl.com OMB Admin Nassau County BOCC Security Level: Email, Account Authentication (None)		Sent: 1/25/2024 9:44:19 AM Viewed: 1/25/2024 10:25:38 AM Signed: 1/25/2024 10:27:39 AM
	Signature Adoption: Pre-selected Style Using IP Address: 50.238.237.26	

Electronic Record and Signature Disclosure:
Not Offered via DocuSign

chris lacambra clacambra@nassaucountyfl.com OMB Director Nassau County BOCC Security Level: Email, Account Authentication (None)		Sent: 1/25/2024 10:27:41 AM Viewed: 1/25/2024 10:38:46 AM Signed: 1/25/2024 10:39:47 AM
	Signature Adoption: Pre-selected Style Using IP Address: 50.238.237.26	

Electronic Record and Signature Disclosure:
Not Offered via DocuSign

Lanaee Gilmore lgilmore@nassaucountyfl.com Procurement Director Nassau County BOCC Security Level: Email, Account Authentication (None)		Sent: 1/25/2024 10:39:50 AM Viewed: 1/26/2024 9:04:16 AM Signed: 1/26/2024 9:04:26 AM
	Signature Adoption: Pre-selected Style Using IP Address: 50.238.237.26	

Electronic Record and Signature Disclosure:
Not Offered via DocuSign

Signer Events	Signature	Timestamp
<p>Abigail Jorandby ajorandby@nassaucountyfl.com Assistant County Attorney Nassau BOCC Security Level: Email, Account Authentication (None)</p> <p>Electronic Record and Signature Disclosure: Not Offered via DocuSign</p>	<p><i>AJ</i></p> <p>Signature Adoption: Pre-selected Style Using IP Address: 50.238.237.26</p>	<p>Sent: 1/26/2024 9:04:29 AM Viewed: 1/30/2024 2:13:36 PM Signed: 1/30/2024 2:14:10 PM</p>
<p>Denise C. May dmay@nassaucountyfl.com Assistant County Attorney Nassau County BOCC Security Level: Email, Account Authentication (None)</p> <p>Electronic Record and Signature Disclosure: Not Offered via DocuSign</p>	<p><i>Denise C. May</i></p> <p>Signature Adoption: Pre-selected Style Using IP Address: 50.238.237.26</p>	<p>Sent: 1/30/2024 2:14:13 PM Viewed: 1/30/2024 2:37:07 PM Signed: 1/30/2024 2:38:18 PM</p>
<p>Taco Pope, AICP tpope@nassaucountyfl.com County Manager Nassau County BOCC Security Level: Email, Account Authentication (None)</p> <p>Electronic Record and Signature Disclosure: Not Offered via DocuSign</p>	<p><i>Taco Pope</i></p> <p>Signature Adoption: Drawn on Device Using IP Address: 50.238.237.26</p>	<p>Sent: 1/30/2024 2:38:21 PM Viewed: 1/30/2024 2:39:04 PM Signed: 1/30/2024 2:39:09 PM</p>
<p>Clerk Finance received boccap@nassauclerk.com Nassau County Clerk Security Level: Email, Account Authentication (None)</p> <p>Electronic Record and Signature Disclosure: Accepted: 2/4/2021 9:59:11 AM ID: 6238f06a-a4ad-4d45-a7f5-929d04629059</p>	<p><i>LPB</i></p> <p>Signature Adoption: Pre-selected Style Using IP Address: 12.23.69.254</p>	<p>Sent: 1/30/2024 2:39:11 PM Viewed: 1/31/2024 11:38:32 AM Signed: 1/31/2024 11:38:49 AM</p>

In Person Signer Events	Signature	Timestamp
Editor Delivery Events	Status	Timestamp
Agent Delivery Events	Status	Timestamp
Intermediary Delivery Events	Status	Timestamp
Certified Delivery Events	Status	Timestamp
Carbon Copy Events	Status	Timestamp
<p>Clerk Services clerkservices@nassaucountyfl.com Security Level: Email, Account Authentication (None)</p> <p>Electronic Record and Signature Disclosure: Accepted: 1/24/2022 11:47:51 AM ID: c578204b-138e-4b31-a24f-82d040e40d69</p>	<div style="border: 2px solid blue; padding: 5px; text-align: center; font-weight: bold; color: blue;">COPIED</div>	<p>Sent: 1/31/2024 11:38:51 AM Viewed: 1/31/2024 11:43:30 AM</p>

Carbon Copy Events	Status	Timestamp
Procurement Dept procurement@nassaucountyfl.com Security Level: Email, Account Authentication (None)	COPIED	Sent: 1/31/2024 11:38:51 AM
Electronic Record and Signature Disclosure:		
Not Offered via DocuSign		

Witness Events	Signature	Timestamp
----------------	-----------	-----------

Notary Events	Signature	Timestamp
---------------	-----------	-----------

Envelope Summary Events	Status	Timestamps
Envelope Sent	Hashed/Encrypted	1/25/2024 9:18:16 AM
Certified Delivered	Security Checked	1/31/2024 11:38:32 AM
Signing Complete	Security Checked	1/31/2024 11:38:49 AM
Completed	Security Checked	1/31/2024 11:38:51 AM

Payment Events	Status	Timestamps
----------------	--------	------------

Electronic Record and Signature Disclosure

ELECTRONIC RECORD AND SIGNATURE DISCLOSURE

From time to time, County of Nassau (we, us or Company) may be required by law to provide to you certain written notices or disclosures. Described below are the terms and conditions for providing to you such notices and disclosures electronically through the DocuSign system. Please read the information below carefully and thoroughly, and if you can access this information electronically to your satisfaction and agree to this Electronic Record and Signature Disclosure (ERSD), please confirm your agreement by selecting the check-box next to 'I agree to use electronic records and signatures' before clicking 'CONTINUE' within the DocuSign system.

Getting paper copies

At any time, you may request from us a paper copy of any record provided or made available electronically to you by us. You will have the ability to download and print documents we send to you through the DocuSign system during and immediately after the signing session and, if you elect to create a DocuSign account, you may access the documents for a limited period of time (usually 30 days) after such documents are first sent to you. After such time, if you wish for us to send you paper copies of any such documents from our office to you, you will be charged a \$0.00 per-page fee. You may request delivery of such paper copies from us by following the procedure described below.

Withdrawing your consent

If you decide to receive notices and disclosures from us electronically, you may at any time change your mind and tell us that thereafter you want to receive required notices and disclosures only in paper format. How you must inform us of your decision to receive future notices and disclosure in paper format and withdraw your consent to receive notices and disclosures electronically is described below.

Consequences of changing your mind

If you elect to receive required notices and disclosures only in paper format, it will slow the speed at which we can complete certain steps in transactions with you and delivering services to you because we will need first to send the required notices or disclosures to you in paper format, and then wait until we receive back from you your acknowledgment of your receipt of such paper notices or disclosures. Further, you will no longer be able to use the DocuSign system to receive required notices and consents electronically from us or to sign electronically documents from us.

All notices and disclosures will be sent to you electronically

Unless you tell us otherwise in accordance with the procedures described herein, we will provide electronically to you through the DocuSign system all required notices, disclosures, authorizations, acknowledgements, and other documents that are required to be provided or made available to you during the course of our relationship with you. To reduce the chance of you inadvertently not receiving any notice or disclosure, we prefer to provide all of the required notices and disclosures to you by the same method and to the same address that you have given us. Thus, you can receive all the disclosures and notices electronically or in paper format through the paper mail delivery system. If you do not agree with this process, please let us know as described below. Please also see the paragraph immediately above that describes the consequences of your electing not to receive delivery of the notices and disclosures electronically from us.

How to contact County of Nassau:

You may contact us to let us know of your changes as to how we may contact you electronically, to request paper copies of certain information from us, and to withdraw your prior consent to receive notices and disclosures electronically as follows:

To contact us by email send messages to: bsimmons@nassaucountyfl.com

To advise County of Nassau of your new email address

To let us know of a change in your email address where we should send notices and disclosures electronically to you, you must send an email message to us at bsimmons@nassaucountyfl.com and in the body of such request you must state: your previous email address, your new email address. We do not require any other information from you to change your email address.

If you created a DocuSign account, you may update it with your new email address through your account preferences.

To request paper copies from County of Nassau

To request delivery from us of paper copies of the notices and disclosures previously provided by us to you electronically, you must send us an email to bsimmons@nassaucountyfl.com and in the body of such request you must state your email address, full name, mailing address, and telephone number. We will bill you for any fees at that time, if any.

To withdraw your consent with County of Nassau

To inform us that you no longer wish to receive future notices and disclosures in electronic format you may:

- i. decline to sign a document from within your signing session, and on the subsequent page, select the check-box indicating you wish to withdraw your consent, or you may;
- ii. send us an email to bsimmons@nassaucountyfl.com and in the body of such request you must state your email, full name, mailing address, and telephone number. We do not need any other information from you to withdraw consent.. The consequences of your withdrawing consent for online documents will be that transactions may take a longer time to process..

Required hardware and software

The minimum system requirements for using the DocuSign system may change over time. The current system requirements are found here: <https://support.docusign.com/guides/signer-guide-signing-system-requirements>.

Acknowledging your access and consent to receive and sign documents electronically

To confirm to us that you can access this information electronically, which will be similar to other electronic notices and disclosures that we will provide to you, please confirm that you have read this ERSD, and (i) that you are able to print on paper or electronically save this ERSD for your future reference and access; or (ii) that you are able to email this ERSD to an email address where you will be able to print on paper or save it for your future reference and access. Further, if you consent to receiving notices and disclosures exclusively in electronic format as described herein, then select the check-box next to ‘I agree to use electronic records and signatures’ before clicking ‘CONTINUE’ within the DocuSign system.

By selecting the check-box next to ‘I agree to use electronic records and signatures’, you confirm that:

- You can access and read this Electronic Record and Signature Disclosure; and
- You can print on paper this Electronic Record and Signature Disclosure, or save or send this Electronic Record and Disclosure to a location where you can print it, for future reference and access; and
- Until or unless you notify County of Nassau as described above, you consent to receive exclusively through electronic means all notices, disclosures, authorizations, acknowledgements, and other documents that are required to be provided or made available to you by County of Nassau during the course of your relationship with County of Nassau.